



ECS GmbH - European Certification Service

Certificate of Compliance

Herewith, ECS certifies that the product(s)

LY600

being an automatic welding filter, variable shade, grinding mode

supplied by the company

**Jiangsu Meixin Optoelectronics Technology Co., Ltd.
(Shanghai Lianya)
Hugang Industrial Zone
Xindian Town Rudong
NANTONG CITY
JIANGSU PROVINCE
P.R.CHINA**

comply with the essential requirements for health and safety. The product meets the requirements for optical and physical properties, luminous transmittance, shades, diffusion of light, switching and holding times, ignition resistance as described in the relevant European and/or international standards as indicated below.

| | |
|----------------------------|--------------------------|
| Standard / technical rules | ANSI / ISEA Z87.1 - 2010 |
| Test report | 11061-ECS-14 |
| Material | plastics, glass |
| Marking | MEIXIN W4 / W9 - W13 |

The validity of this certificate of compliance (CoC) may be compromised if the manufacturer changes the safety related properties of the product or if the Standard referred to is modified or updated.

As a recognised and authorised testing laboratory / facility, we hereby authorise the use of our name, address and the identification number 1883 of the notified body ECS in marketing and information material produced by the manufacturer.

ECS GmbH
Notified Body 1883
05/09/14

Dr. Bernhard Schmitz
ECS-Certification



ECS GmbH – European Certification Service
Augenschutz und Persönliche Schutzausrüstung
Laserschutz und Optische Messtechnik
Hüttfeldstraße 50
73430 Aalen, Germany

Certificate of Compliance

Herewith, ECS certifies that the product(s)

LYG-5
being welding helmet, face shield for welding
and allied processes

supplied by the company

Jiangsu Meixin Optoelectronics
Technology Co., Ltd (Shanghai Lianya)
Hugang Industrial Zone
Xindian Town Rudong
NANTONG CITY
JIANGSU PROVINCE
P.R.CHINA

comply with the essential requirements for health and safety. The product meets the requirements for optical and physical properties, ignition and flame resistance as they are described in the relevant European and / or International standards as indicated below.

Standard / technical rules ANSI / ISEA Z87.1 - 2015

Test report 11733-ECS-15

Material Polyamide

Marking MEIXIN Z87

The validity of this certificate of compliance (CoC) may be compromised if the manufacturer changes the safety related properties of the product or if the Standard referred to is modified or updated.

As a recognised and authorised testing laboratory / facility, we hereby authorise the use of our name, address and the identification number 1883 of the notified body ECS in marketing and information material produced by the manufacturer.

ECS GmbH
Notified Body 1883
27/11/15

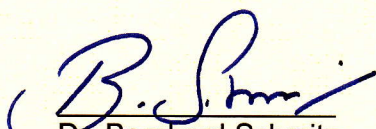

Dr. Bernhard Schmitz
ECS-Certification



ECS GmbH – European Certification Service
Augenschutz und Persönliche Schutzausrüstung
Laserschutz und Optische Messtechnik
Hüttfeldstraße 50
73430 Aalen, Germany

EC-type examination certificate

C1771.2MEIXIN

| | |
|------------------------------------|---|
| Applicant / manufacturer | Jiangsu Meixin Optoelectronics Technology Co. Ltd. (Shanghai Lianya) Hugang Industrial Zone Xindian Town, Rudong NANTONG CITY JIANGSU PROVINCE P.R.CHINA |
| Identification of the manufacturer | MEIXIN |
| Product type | Automatic welding filter, variable shade, grinding mode |
| Model name | LY600 |
| Standard(s) / technical rules | DIN EN 379 : 2003 + A1 : 2009 Essential requirements according to Annex II of the PPE-Directive 89/686/EEC |
| Test report | 11061-ECS-14 |
| Specifications | Optical class: 1 Diffusion of light class: 1 Variations in luminous transmittance class: 1 Angle dependence of luminous transmittance: 1 |
| Marking | 4 / 9-13 MEIXIN 1/1/1/1/379 CE |

Herewith, ECS certifies that the named model complies with the basic requirements for health and safety as they are provided by the European Directive for Personal Protective Equipment 89/686/EEC. This certificate is based both / either on the test results as they are summarized in the named test reports, and/or on the technical documentation as it is delivered by the manufacturer. The applicant / manufacturer agree to the General Business Rules of the ECS GmbH and to additional agreements as they are named in the application for conformity assessment.

The eye-protection device is to be marked as assigned. Either / both the frame and / or the ocular, spectacle, goggle or shield must be signed, as appropriate. If different marking has been assessed, the lowest marking must be applied, respectively.

The validity of this EC-type examination will expire on the date as mentioned below, and if the manufacturer modifies the safety-relevant properties of this product with comparison to the tested one or if the requirements in the standards or technical rules will be revised and/or tightened.

Name, address and identification number 1883 of the notified body ECS are to be indicated in the information brochure of this product.

This EC-type examination certificate is valid until 2019-09.

ECS GmbH
Notified Body 1883
06/11/14



Dr. Bernhard Schmitz
ECS-Certification



ECS GmbH – European Certification Service
Augenschutz und Persönliche Schutzausrüstung
Laserschutz und Optische Messtechnik
Hüttfeldstraße 50
73430 Aalen, Germany

Test mark: 11061-ECS-14

Type: LY600 / AWF variable shade

Remark:

The shade number scaling is customized individually for each AWF.

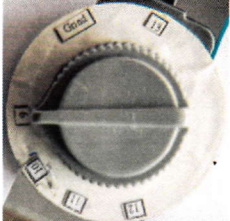
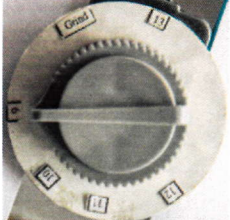
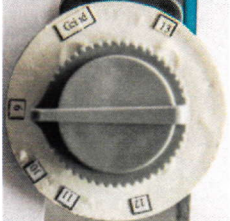
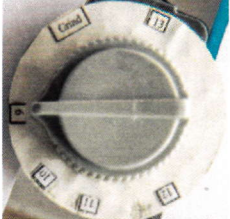
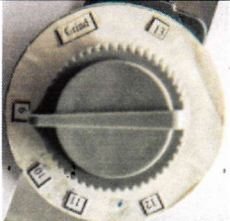
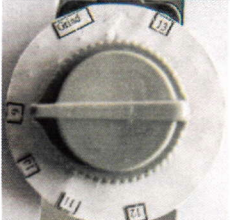
| Sample | Scale |
|---------|--|
| 14106-1 |  |
| 14106-2 |  |
| 14106-3 |  |
| 14106-4 |  |
| 14106-5 |  |
| 14106-6 |  |

Test mark: 11061-ECS-14

Type: LY600 / AWF variable shade

Quality of material and surface, refractive powers, transmittance

| test ↓ sample → | | 14106 | | | | | |
|--|------|-------|------|-----|------|------|-------|
| | | -1 | -2 | -3 | -4 | -5 | -6 |
| quality of material and surface | | + | + | + | + | + | + |
| prismatic power (horizontal/vertical) | cm/m | 0/0 | 0/0 | 0/0 | 0/0 | 0/0 | 0/0 |
| spherical power | dpt | 0.01 | 0.01 | 0 | 0 | 0 | -0.01 |
| astigmatic power | dpt | 0.01 | 0 | 0 | 0.01 | 0.01 | 0.01 |
| optical class | | 1 | 1 | 1 | 1 | 1 | 1 |
| luminous transmittance rel NA * horizontal orientation | % | 2.4 | 2.4 | 2.4 | 2.4 | 2.4 | 2.4 |
| calculated shade number | | 4.8 | 4.8 | 4.8 | 4.8 | 4.8 | 4.8 |
| nominal shade number | | 5 | 5 | 5 | 5 | 5 | 5 |
| luminous transmittance rel NA * vertical orientation | % | 6.4 | 6.2 | 6.5 | 6.4 | 6.5 | 6.5 |
| calculated shade number | | 3.8 | 3.8 | 3.8 | 3.8 | 3.8 | 3.8 |
| nominal shade number | | 4 | 4 | 4 | 4 | 4 | 4 |

* measured in a spectrophotometer, whereat the light is partially polarized. Therefore, the luminous transmittance and the shade numbers, respectively, can be only a rough estimation.

Test mark: 11061-ECS-14

Type: LY600 / AWF variable shade

Diffusion of light / reduced luminance coefficient

| test ↓ sample → | | 14106 | | | | | |
|--|-----------------------------------|-------|-----|-----|-----|-----|-----|
| | | -1 | -2 | -3 | -4 | -5 | -6 |
| reduced luminance coefficient, diffusion of light, clear state | $\frac{\text{cd/m}^2}{\text{lx}}$ | 0.1 | 0.2 | 0.1 | 0.1 | 0.2 | 0.1 |
| diffusion of light class | | 1 | 1 | 1 | 1 | 1 | 1 |
| reduced luminance coefficient, diffusion of light, shade number 9 | $\frac{\text{cd/m}^2}{\text{lx}}$ | 0.1 | 0.1 | 0.1 | 0.1 | 0.1 | 0.1 |
| diffusion of light class | | 1 | 1 | 1 | 1 | 1 | 1 |
| reduced luminance coefficient, diffusion of light, shade number 10 | $\frac{\text{cd/m}^2}{\text{lx}}$ | 0.1 | 0.2 | 0.1 | 0.1 | 0.2 | 0.1 |
| diffusion of light class | | 1 | 1 | 1 | 1 | 1 | 1 |
| reduced luminance coefficient, diffusion of light, shade number 11 | $\frac{\text{cd/m}^2}{\text{lx}}$ | 0.2 | 0.2 | 0.1 | 0.2 | 0.2 | 0.1 |
| diffusion of light class | | 1 | 1 | 1 | 1 | 1 | 1 |
| reduced luminance coefficient, diffusion of light, shade number 12 | $\frac{\text{cd/m}^2}{\text{lx}}$ | 0.2 | 0.2 | 0.2 | 0.2 | 0.1 | 0.1 |
| diffusion of light class | | 1 | 1 | 1 | 1 | 1 | 1 |
| reduced luminance coefficient, diffusion of light, shade number 13 | $\frac{\text{cd/m}^2}{\text{lx}}$ | 0.2 | 0.3 | 0.2 | 0.2 | 0.2 | 0.2 |
| diffusion of light class | | 1 | 1 | 1 | 1 | 1 | 1 |

| | |
|------------|----------------------------|
| Test mark: | 11061-ECS-14 |
| Type: | LY600 / AWF variable shade |

Filtering action

| test ↓ | | sample → | | 14106 | | | | | |
|------------------------------------|---|------------------------------|------------------------------|------------------------------|------------------------------|------------------------------|------------------------------|------------------------------|------------------------------|
| | | | | -1 | -2 | -3 | -4 | -5 | -6 |
| luminous transmittance rel NA * | % | 2.4 | 2.4 | 2.4 | 2.4 | 2.4 | 2.4 | 2.4 | 2.4 |
| horizontal orientation | | | | | | | | | |
| calculated shade number | | 4.8 | 4.8 | 4.8 | 4.8 | 4.8 | 4.8 | 4.8 | 4.8 |
| nominal shade number | | 5 | 5 | 5 | 5 | 5 | 5 | 5 | 5 |
| luminous transmittance rel NA * | % | 6.4 | 6.2 | 6.5 | 6.4 | 6.5 | 6.5 | 6.5 | 6.5 |
| vertical orientation | | | | | | | | | |
| calculated shade number | | 3.8 | 3.8 | 3.8 | 3.8 | 3.8 | 3.8 | 3.8 | 3.8 |
| nominal shade number | | 4 | 4 | 4 | 4 | 4 | 4 | 4 | 4 |
| EN 169 and EN 379 | | | | | | | | | |
| spectral transmittance | % | $\leq 3 \cdot 10^{-4}$ | $\leq 3 \cdot 10^{-4}$ | $\leq 3 \cdot 10^{-4}$ | $\leq 3 \cdot 10^{-4}$ | $\leq 3 \cdot 10^{-4}$ | $\leq 3 \cdot 10^{-4}$ | $\leq 3 \cdot 10^{-4}$ | $\leq 3 \cdot 10^{-4}$ |
| 210 nm $\leq \lambda \leq 313$ nm | | | | | | | | | |
| spectral transmittance | % | $\leq 4.4 \cdot 10^{-4}$ | $\leq 4.4 \cdot 10^{-4}$ | $\leq 4.4 \cdot 10^{-4}$ | $\leq 4.4 \cdot 10^{-4}$ | $\leq 4.4 \cdot 10^{-4}$ | $\leq 4.4 \cdot 10^{-4}$ | $\leq 4.4 \cdot 10^{-4}$ | $\leq 4.4 \cdot 10^{-4}$ |
| 313 nm $< \lambda \leq 365$ nm | | | | | | | | | |
| spectral transmittance | | $\leq \tau$ | $\leq \tau$ | $\leq \tau$ | $\leq \tau$ | $\leq \tau$ | $\leq \tau$ | $\leq \tau$ | $\leq \tau$ |
| 365 nm $< \lambda \leq 380$ nm | | | | | | | | | |
| spectral transmittance | | $\leq \tau_{(480\text{nm})}$ | $\leq \tau_{(480\text{nm})}$ | $\leq \tau_{(480\text{nm})}$ | $\leq \tau_{(480\text{nm})}$ | $\leq \tau_{(480\text{nm})}$ | $\leq \tau_{(480\text{nm})}$ | $\leq \tau_{(480\text{nm})}$ | $\leq \tau_{(480\text{nm})}$ |
| 380 nm $< \lambda \leq 480$ nm | | | | | | | | | |
| mean transmittance | % | ≤ 0.014 | ≤ 0.014 | ≤ 0.014 | ≤ 0.014 | ≤ 0.014 | ≤ 0.014 | ≤ 0.014 | ≤ 0.014 |
| 780 nm $\leq \lambda \leq 1400$ nm | | | | | | | | | |

Remark: the samples meet the requirements in the UV- and IR-range for the dark state already in the clear state.

* measured in a spectrophotometer, whereat the light is partially polarized

Continued at the next page!

| | |
|------------|----------------------------|
| Test mark: | 11061-ECS-14 |
| Type: | LY600 / AWF variable shade |

Filtering action (continued)

| test ↓ | sample → | 14106 | | | | | |
|--|----------|---------------------------------|---------------------------------|---------------------------------|---------------------------------|---------------------------------|---------------------------------|
| | | -1 | -2 | -3 | -4 | -5 | -6 |
| ANSI / ISEA Z87.1-2010 & CSA Z94.3-07 | | | | | | | |
| effective FUV transmittance 200 nm ≤ λ ≤ 315 nm | % | ≤2*10 ⁻⁴ | ≤2*10 ⁻⁴ | ≤2*10 ⁻⁴ | ≤2*10 ⁻⁴ | ≤2*10 ⁻⁴ | ≤2*10 ⁻⁴ |
| mean near UV transmittance 315 nm ≤ λ ≤ 385 nm | % | ≤τ _L /10 | ≤τ _L /10 | ≤τ _L /10 | ≤τ _L /10 | ≤τ _L /10 | ≤τ _L /10 |
| blue-light transmittance 400 nm ≤ λ ≤ 1400 nm | % | τ _b < τ _L | τ _b < τ _L | τ _b < τ _L | τ _b < τ _L | τ _b < τ _L | τ _b < τ _L |
| mean IR transmittance 780 nm ≤ λ ≤ 2000 nm | % | ≤0.4 | ≤0.4 | ≤0.4 | ≤0.4 | ≤0.4 | ≤0.4 |
| AS/NZS 1338.1:2012 | | | | | | | |
| spectral transmittance 210 nm ≤ λ ≤ 313 nm | % | ≤76*10 ⁻⁶ | ≤76*10 ⁻⁶ | ≤76*10 ⁻⁶ | ≤76*10 ⁻⁶ | ≤76*10 ⁻⁶ | ≤76*10 ⁻⁶ |
| spectral transmittance 313 nm < λ ≤ 365 nm | % | ≤76*10 ⁻⁶ | ≤76*10 ⁻⁶ | ≤76*10 ⁻⁶ | ≤76*10 ⁻⁶ | ≤76*10 ⁻⁶ | ≤76*10 ⁻⁶ |
| spectral transmittance 365 nm < λ ≤ 380 nm | | ≤τ | ≤τ | ≤τ | ≤τ | ≤τ | ≤τ |
| mean IR transmittance 800 nm ≤ λ ≤ 2000 nm | % | ≤0.4 | ≤0.4 | ≤0.4 | ≤0.4 | ≤0.4 | ≤0.4 |
| ISO/WD 16321 N141 | | | | | | | |
| spectral transmittance 200 nm ≤ λ ≤ 313 nm | % | ≤3*10 ⁻⁴ | ≤3*10 ⁻⁴ | ≤3*10 ⁻⁴ | ≤3*10 ⁻⁴ | ≤3*10 ⁻⁴ | ≤3*10 ⁻⁴ |
| spectral transmittance 313 nm < λ ≤ 365 nm | % | ≤4.4*10 ⁻⁴ | ≤4.4*10 ⁻⁴ | ≤4.4*10 ⁻⁴ | ≤4.4*10 ⁻⁴ | ≤4.4*10 ⁻⁴ | ≤4.4*10 ⁻⁴ |
| blue-light transmittance | % | < 3.6 | < 3.6 | < 3.6 | < 3.6 | < 3.6 | < 3.6 |
| spectral transmittance 365 nm < λ ≤ 380 nm | % | ≤τ | ≤τ | ≤τ | ≤τ | ≤τ | ≤τ |
| mean transmittance 780 nm ≤ λ ≤ 1400 nm | % | ≤1 | ≤1 | ≤1 | ≤1 | ≤1 | ≤1 |
| mean transmittance 780 nm ≤ λ ≤ 3000 nm | % | ≤1 | ≤1 | ≤1 | ≤1 | ≤1 | ≤1 |

Remark: the samples meet the requirements in the UV- and IR-range for the dark state already in the clear state.

* measured in a spectrophotometer, whereat the light is partially polarized..

| | |
|------------|----------------------------|
| Test mark: | 11061-ECS-14 |
| Type: | LY600 / AWF variable shade |

Homogeneity, variations in luminous transmittance

| test ↓ sample → | | 14106 | | | | | |
|--|---|-----------|-----------|-----------|-----------|-----------|-----------|
| | | -1 | -2 | -3 | -4 | -5 | -6 |
| homogeneity, clear state, P1 | % | 4.9 | 3.9 | 3.2 | 9.8 | 2.5 | 9.4 |
| homogeneity, clear state, P2 | % | 4.1 | 4.2 | 3.0 | 8.0 | 3.3 | 5.2 |
| homogeneity, clear state, P3 | % | 0.4 | 0.1 | 0.9 | 0.3 | 0.9 | 1.9 |
| variations in luminous transmittance class | | 1 | 1 | 1 | 1 | 1 | 1 |
| ANSI Z87.1, ratio value, left/right | | 1.00 | 1.00 | 0.99 | 1.00 | 1.01 | 1.02 |
| CSA Z94.3, maximal ratio value | | 0.95 | 0.95 | 0.96 | 0.92 | 0.96 | 0.90 |
| CSA Z94.3, minimal ratio value | | 1.00 | 1.02 | 1.01 | 1.01 | 1.00 | 1.01 |
| measured shade numbers, limits | | 4.08-4.14 | 4.09-4.16 | 4.10-4.15 | 4.06-4.16 | 4.12-4.15 | 4.05-4.17 |
| homogeneity, shade number 9, P1 | % | 16.6 | 12.7 | 9.3 | 23.1 | 11.2 | 27.0 |
| homogeneity, shade number 9, P2 | % | 12.8 | 11.1 | 10.6 | 22.2 | 6.2 | 13.0 |
| homogeneity, shade number 9, P3 | % | 2.2 | 1.2 | 3.7 | 0.3 | 1.9 | 6.4 |
| variations in luminous transmittance class | | 2 | 1 | 1 | 3 | 1 | 3 |
| ANSI Z87.1, ratio value, left/right | | 0.98 | 0.99 | 0.96 | 1.00 | 0.98 | 1.07 |
| CSA Z94.3, maximal ratio value | | 0.85 | 0.92 | 0.89 | 0.81 | 0.92 | 0.72 |
| CSA Z94.3, minimal ratio value | | 1.01 | 1.09 | 1.03 | 1.07 | 1.04 | 1.03 |
| measured shade numbers, limits | | 8.64-8.81 | 8.54-8.73 | 8.64-8.79 | 8.33-8.61 | 8.53-8.65 | 8.33-8.69 |

Continued at the next page!

| | |
|------------|----------------------------|
| Test mark: | 11061-ECS-14 |
| Type: | LY600 / AWF variable shade |

Homogeneity, variations in luminous transmittance (continued)

| test ↓ sample → | | 14106 | | | | | |
|--|---|-------------|-------------|--------------------|--------------------|--------------------|--------------------|
| | | -1 | -2 | -3 | -4 | -5 | -6 |
| homogeneity, shade number 10, P1 | % | 17.8 | 13.7 | 10.4 | 26.6 | 10.5 | 28.8 |
| homogeneity, shade number 10, P2 | % | 15.4 | 12.5 | 12.4 | 25.6 | 7.5 | 15.4 |
| homogeneity, shade number 10, P3 | % | 0.7 | 0.9 | 3.4 | 0.3 | 0.9 | 6.5 |
| variations in luminous transmittance class | | 1 | 1 | 1 | 3 | 1 | 3 |
| ANSI Z87.1, ratio value, left/right | | 1.07 | 0.99 | 0.99 | 0.97 | 1.00 | 1.01 |
| CSA Z94.3, maximal ratio value | | 0.84 | 0.91 | 0.88 | 0.80 | 0.90 | 0.70 |
| CSA Z94.3, minimal ratio value | | 1.01 | 1.10 | 1.04 | 1.08 | 1.02 | 1.04 |
| measured shade numbers, limits | | 9.45-9.65 | 9.48-9.68 | 9.55-9.72 | 9.29-9.60 | 9.44-9.57 | 8.94-9.33 |
| homogeneity, shade number 11, P1 | % | 18.9 | 13.0 | 9.8 | 26.0 | 12.1 | 32.4 |
| homogeneity, shade number 11, P2 | % | 15.8 | 12.6 | 13.6 | 25.1 | 7.7 | 15.6 |
| homogeneity, shade number 11, P3 | % | 0.7 | 0.2 | 2.1 | 1.1 | 0.4 | 8.3 |
| variations in luminous transmittance class | | 1 | 1 | 1 | 2 | 1 | 3 |
| ANSI Z87.1, ratio value, left/right | | 0.99 | 1.00 | 0.98 | 1.01 | 1.00 | 1.09 |
| CSA Z94.3, maximal ratio value | | 0.83 | 0.91 | 0.87 | 0.80 | 0.89 | 0.68 |
| CSA Z94.3, minimal ratio value | | 1.01 | 1.10 | 1.05 | 1.08 | 1.02 | 1.03 |
| measured shade numbers, limits | | 10.62-10.82 | 10.56-10.76 | 10.48-10.67 | 10.36-10.68 | 10.38-10.52 | 10.09-10.51 |

Continued at the next page!

Test mark: 11061-ECS-14

Type: LY600 / AWF variable shade

Homogeneity, variations in luminous transmittance (continued)

| test ↓ sample → | | 14106 | | | | | |
|--|---|-------------|-------------|-------------|-------------|-------------|--------------------|
| | | -1 | -2 | -3 | -4 | -5 | -6 |
| homogeneity, shade number 12, P1 | % | 16.1 | 13.4 | 7.7 | 23.5 | 10.2 | 30.0 |
| homogeneity, shade number 12, P2 | % | 16.4 | 11.2 | 12.2 | 21.1 | 6.8 | 13.2 |
| homogeneity, shade number 12, P3 | % | 1.4 | 1.4 | 0.1 | 0.2 | 1.4 | 6.7 |
| variations in luminous transmittance class | | 1 | 1 | 1 | 1 | 1 | 1 |
| ANSI Z87.1, ratio value, left/right | | 1.01 | 0.99 | 1.00 | 1.00 | 1.01 | 1.07 |
| CSA Z94.3, maximal ratio value | | 0.84 | 0.92 | 0.89 | 0.82 | 0.91 | 0.70 |
| CSA Z94.3, minimal ratio value | | 1.01 | 1.10 | 1.06 | 1.10 | 1.02 | 1.04 |
| measured shade numbers, limits | | 11.50-11.69 | 11.61-11.79 | 11.69-11.87 | 11.51-11.82 | 11.53-11.66 | 11.27-11.66 |
| homogeneity, shade number 13, P1 | % | 12.8 | 10.4 | 5.1 | 17.3 | 7.6 | 15.4 |
| homogeneity, shade number 13, P2 | % | 14.6 | 8.4 | 10.0 | 15.4 | 5.5 | 9.7 |
| homogeneity, shade number 13, P3 | % | 2.3 | 2.9 | 1.7 | 0.2 | 2.1 | 5.1 |
| variations in luminous transmittance class | | 1 | 1 | 1 | 1 | 1 | 1 |
| ANSI Z87.1, ratio value, left/right | | 1.02 | 0.97 | 1.02 | 1.00 | 1.02 | 1.05 |
| CSA Z94.3, maximal ratio value | | 0.86 | 0.94 | 0.93 | 0.86 | 0.92 | 0.82 |
| CSA Z94.3, minimal ratio value | | 1.01 | 1.10 | 1.06 | 1.09 | 1.02 | 1.02 |
| measured shade numbers, limits | | 12.79-12.96 | 12.76-12.92 | 12.81-12.95 | 12.64-12.88 | 12.74-12.84 | 12.64-12.87 |

Continued at the next page!

Test mark: 11061-ECS-14

Type: LY600 / AWF variable shade

Homogeneity, variations in luminous transmittance (continued)

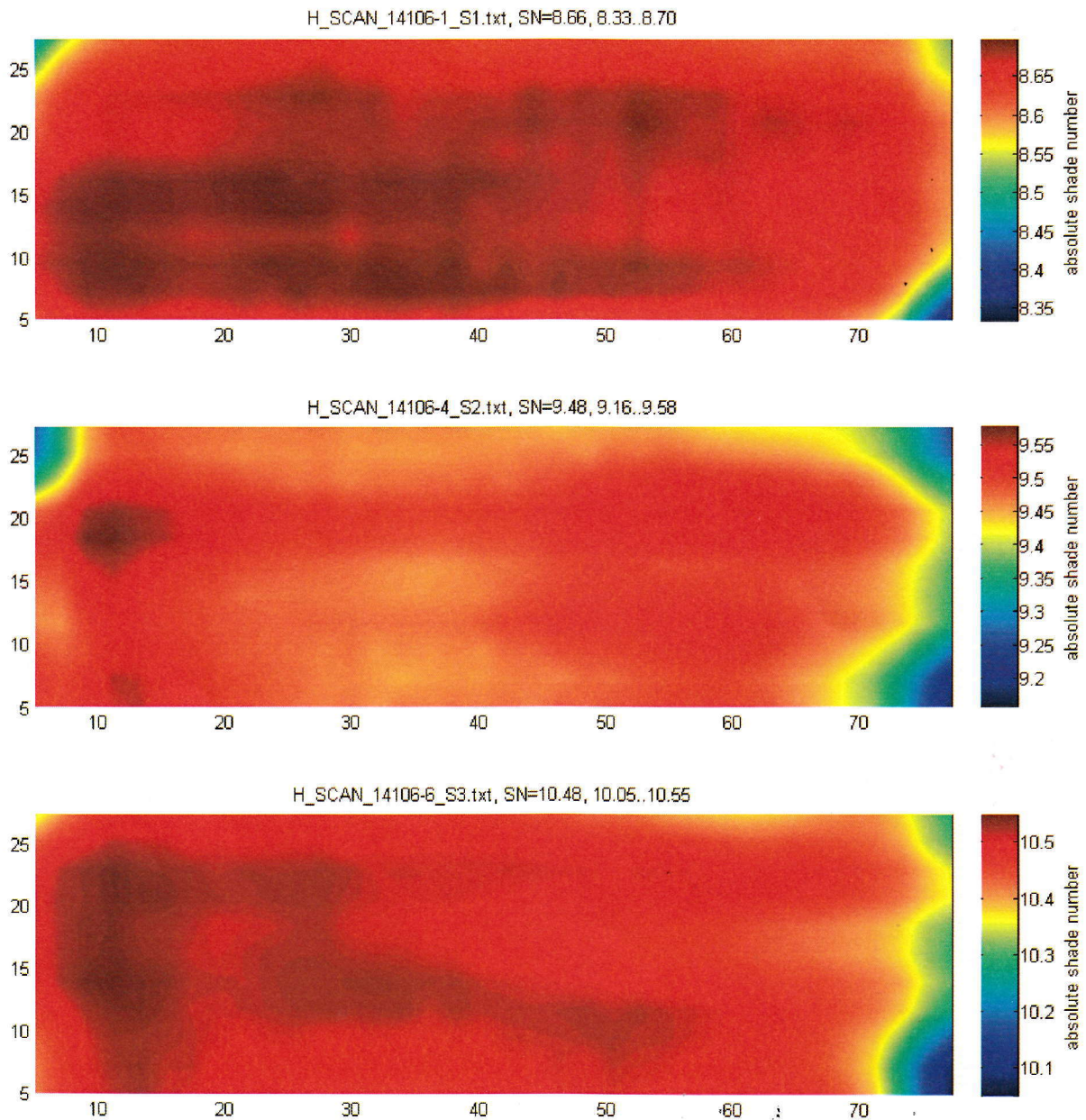

Figure 1: homogeneity measurement of sample 14106-1 at shade number 9, sample 14106-4 at shade number 10 and sample 14106-6 at shade number 11.

Continued at the next page!

Test mark: 11061-ECS-14

Type: LY600 / AWF variable shade

Homogeneity, variations in luminous transmittance (continued)

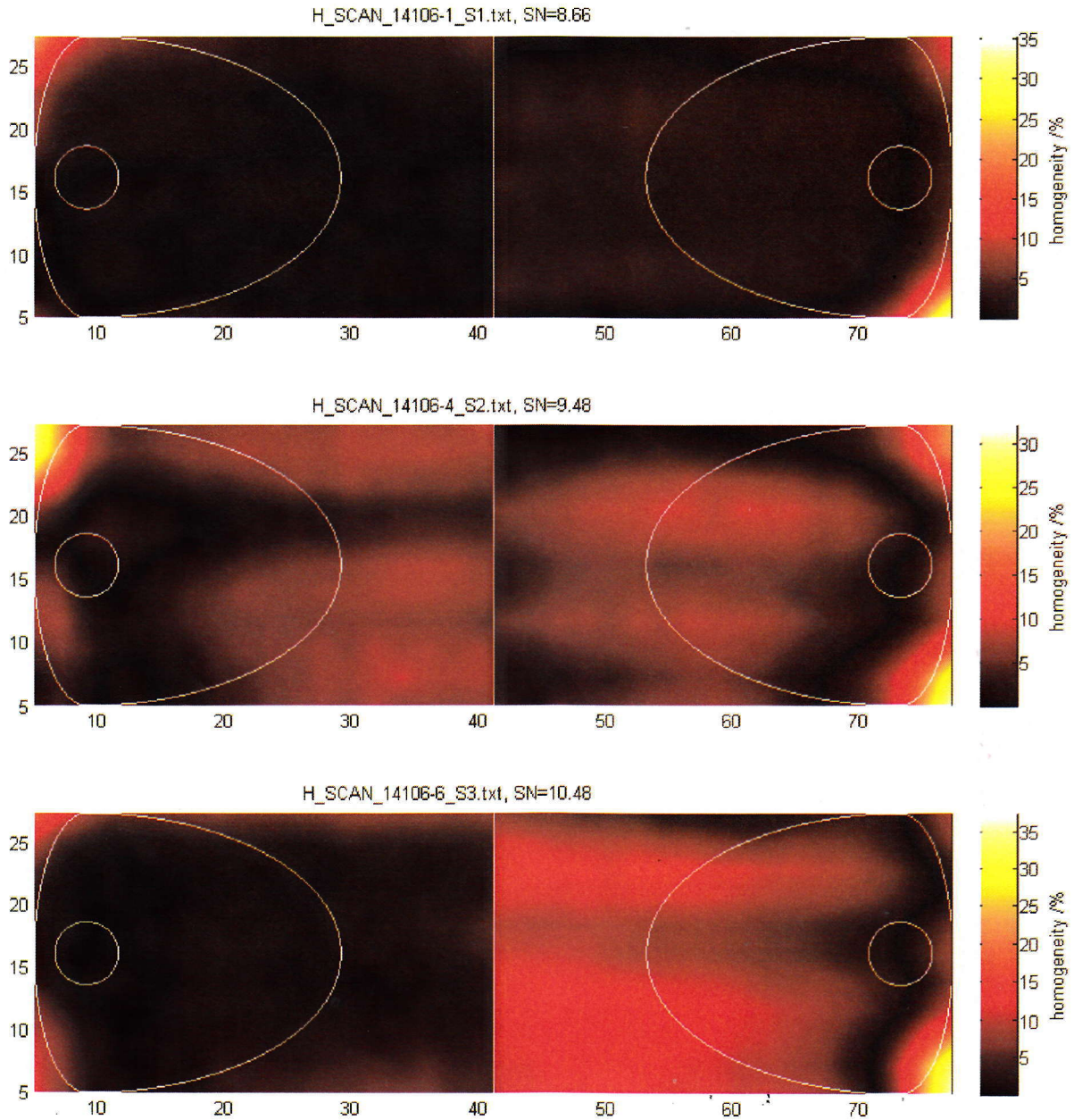

Figure 2: homogeneity evaluation of sample 14106-1 at shade number 9, sample 14106-4 at shade number 10 and sample 14106-6 at shade number 11.

Continued at the next page!

Test mark: 11061-ECS-14

Type: LY600 / AWF variable shade

Homogeneity, variations in luminous transmittance (continued)

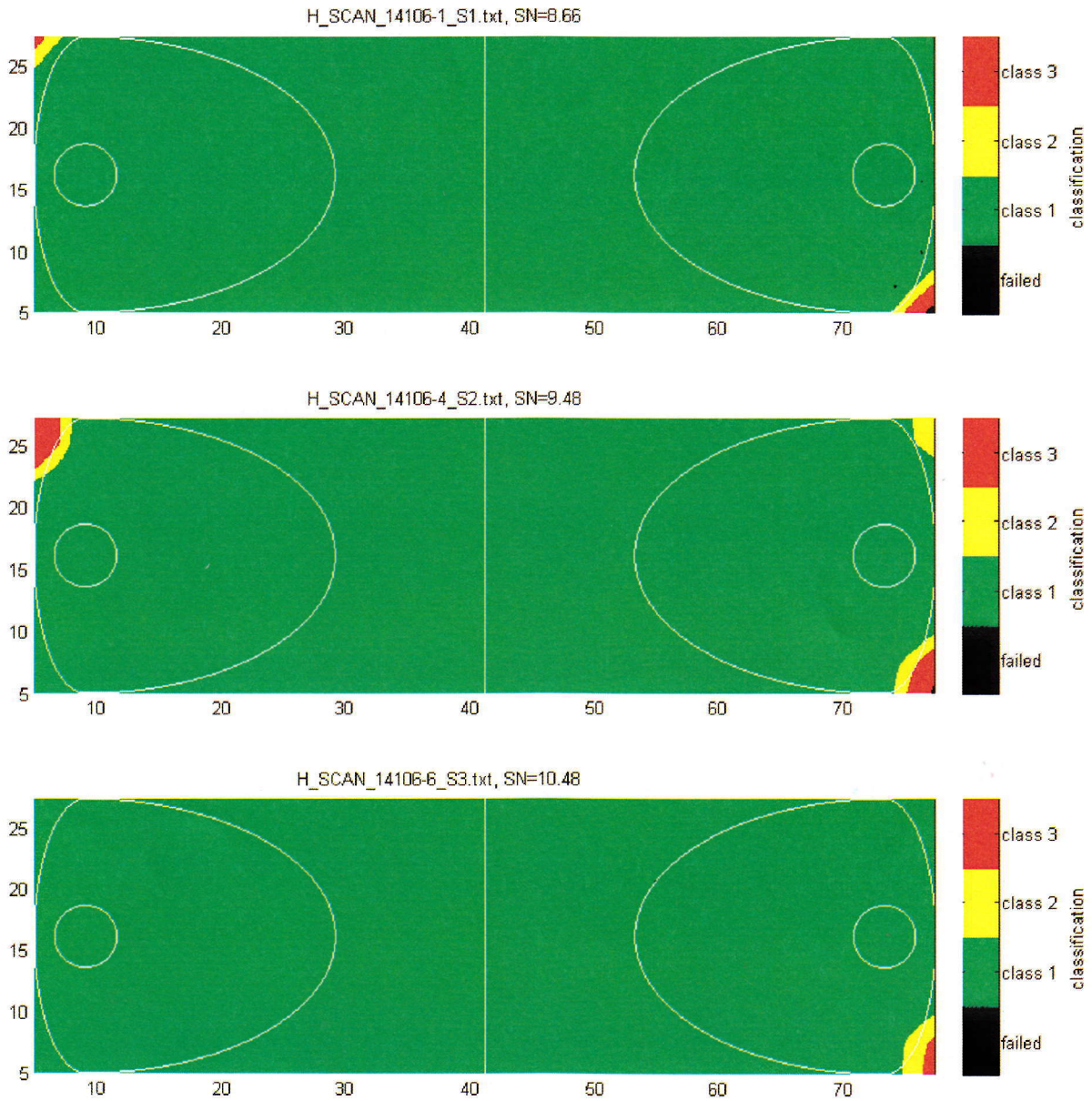

Figure 3: homogeneity classification of sample 14106-1 at shade number 9, sample 14106-4 at shade number 10 and sample 14106-6 at shade number 11.

| | |
|------------|----------------------------|
| Test mark: | 11061-ECS-14 |
| Type: | LY600 / AWF variable shade |

Luminous transmittance variation over time

ISO/WD 16321 N141

| test ↓ sample → | | 14106 | | | | | |
|----------------------|---|-------|-----|-----|-----|-----|-----|
| | | -1 | -2 | -3 | -4 | -5 | -6 |
| shade number 9 | % | ≤30 | ≤30 | ≤30 | ≤30 | ≤30 | ≤30 |
| shade number 10 | % | ≤30 | ≤30 | ≤30 | ≤30 | ≤30 | ≤30 |
| shade number 11 | % | ≤30 | ≤30 | ≤30 | ≤30 | ≤30 | ≤30 |
| shade number 12 | % | ≤30 | ≤30 | ≤30 | ≤30 | ≤30 | ≤30 |
| shade number 13 | % | ≤40 | ≤40 | ≤40 | ≤40 | ≤40 | ≤40 |

Sensitivity Test

ISO/WD 16321 N141

| Test ↓ sample → | | 14106 | | | | | |
|----------------------|--|-------|----|----|----|----|----|
| | | -1 | -2 | -3 | -4 | -5 | -6 |
| indoor light | | + | + | + | + | + | + |
| outdoor light | | + | + | + | + | + | + |

Test mark: 11061-ECS-14

Type: LY600 / AWF variable shade

Luminous transmittance / shade number at extremes of temperatures (continued)

| test ↓ sample → | 14106 | | | | | |
|---|-------|------|------|------|------|-------------|
| | -1 | -2 | -3 | -4 | -5 | -6 |
| temperature: -5°C | | | | | | |
| luminous transmittance / shade number clear | 4.1 | 4.1 | 4.1 | 4.1 | 4.1 | 4.1 |
| luminous transmittance / shade number 9 | 9.0 | 8.9 | 9.1 | 8.9 | 8.9 | 9.0 |
| luminous transmittance / shade number 10 | 9.8 | 9.7 | 9.9 | 9.6 | 9.7 | 9.6 |
| luminous transmittance / shade number 11 | 10.9 | 10.7 | 10.8 | 10.5 | 10.6 | 10.7 |
| luminous transmittance / shade number 12 | 11.7 | 11.7 | 11.9 | 11.6 | 11.7 | 11.7 |
| luminous transmittance / shade number 13 | 12.9 | 12.8 | 13.0 | 12.8 | 12.8 | 12.9 |
| temperature: RT | | | | | | |
| luminous transmittance / shade number clear | 4.1 | 4.1 | 4.1 | 4.1 | 4.1 | 4.1 |
| luminous transmittance / shade number 9 | 8.8 | 8.6 | 8.7 | 8.5 | 8.6 | 8.6 |
| luminous transmittance / shade number 10 | 9.6 | 9.6 | 9.7 | 9.5 | 9.5 | 9.2 |
| luminous transmittance / shade number 11 | 10.8 | 10.7 | 10.6 | 10.6 | 10.5 | 10.4 |
| luminous transmittance / shade number 12 | 11.6 | 11.7 | 11.8 | 11.7 | 11.6 | 11.5 |
| luminous transmittance / shade number 13 | 12.9 | 12.8 | 12.9 | 12.8 | 12.8 | 12.8 |

Continued at the next page!

| | |
|------------|----------------------------|
| Test mark: | 11061-ECS-14 |
| Type: | LY600 / AWF variable shade |

Luminous transmittance / shade number at extremes of temperatures (continued)

| test ↓ sample → | 14106 | | | | | |
|--|-------|------|------|------|------|------|
| | -1 | -2 | -3 | -4 | -5 | -6 |
| temperature: +55°C | | | | | | |
| luminous transmittance / shade number clear | 4.4 | 4.5 | 4.5 | 4.5 | 4.5 | 4.5 |
| luminous transmittance / shade number 9 | 8.8 | 8.7 | 8.7 | 8.7 | */* | 8.7 |
| luminous transmittance / shade number 10 | 9.8 | 9.6 | 9.6 | 9.7 | 9.8 | 9.3 |
| luminous transmittance / shade number 11 | 10.9 | 10.8 | 10.6 | 10.7 | 10.7 | 10.4 |
| luminous transmittance / shade number 12 | 11.6 | 11.8 | 11.8 | 11.8 | 11.8 | 11.6 |
| luminous transmittance / shade number 13 | 12.1 | 12.9 | 12.8 | 12.8 | 12.9 | 12.8 |

| | |
|------------|----------------------------|
| Test mark: | 11061-ECS-14 |
| Type: | LY600 / AWF variable shade |

Switching and delay time

| type: | switching time | | | delay time | | |
|-----------------|----------------|-------|-----|------------|-------|----|
| | temperature: | -5 °C | RT | +55 °C | -5 °C | RT |
| unit: | ms | ms | ms | ms | ms | ms |
| sample 14106-1 | | | | | | |
| shade number 9 | 0.7 | 0.2 | 0.2 | 250 | 140 | 60 |
| shade number 10 | 0.7 | 0.3 | 0.2 | 250 | 130 | 70 |
| shade number 11 | 0.7 | 0.3 | 0.2 | 260 | 130 | 60 |
| shade number 12 | 0.7 | 0.3 | 0.2 | 260 | 130 | 60 |
| shade number 13 | 0.8 | 0.3 | 0.2 | 270 | 140 | 70 |
| sample 14106-2 | | | | | | |
| shade number 9 | 0.7 | 0.3 | 0.3 | 230 | 120 | 60 |
| shade number 10 | 0.8 | 0.3 | 0.3 | 240 | 130 | 60 |
| shade number 11 | 0.7 | 0.3 | 0.5 | 240 | 130 | 60 |
| shade number 12 | 0.8 | 0.3 | 0.6 | 240 | 120 | 60 |
| shade number 13 | 0.8 | 0.3 | 0.1 | 250 | 130 | 60 |
| sample 14106-3 | | | | | | |
| shade number 9 | 4.0 | 0.3 | 0.3 | 250 | 140 | 60 |
| shade number 10 | 0.8 | 0.3 | 0.3 | 250 | 130 | 60 |
| shade number 11 | 0.7 | 0.3 | 0.3 | 260 | 130 | 60 |
| shade number 12 | 0.7 | 0.3 | 0.3 | 260 | 130 | 60 |
| shade number 13 | 0.7 | 0.3 | 0.4 | 270 | 130 | 60 |

Continued at the next page!

| | |
|------------|----------------------------|
| Test mark: | 11061-ECS-14 |
| Type: | LY600 / AWF variable shade |

Switching and delay time (continued)

| type: | switching time | | | delay time | | |
|-----------------|----------------|-------|-----|------------|-------|----|
| | temperature: | -5 °C | RT | +55 °C | -5 °C | RT |
| unit: | ms | ms | ms | ms | ms | ms |
| sample 14106-4 | | | | | | |
| shade number 9 | 0.7 | 0.3 | 0.4 | 230 | 120 | 60 |
| shade number 10 | 0.8 | 0.3 | 0.3 | 240 | 120 | 60 |
| shade number 11 | 0.7 | 0.3 | 0.3 | 240 | 120 | 60 |
| shade number 12 | 3.9 | 0.3 | 0.2 | 240 | 120 | 60 |
| shade number 13 | 3.8 | 0.3 | 0.2 | 250 | 120 | 60 |
| sample 14106-5 | | | | | | |
| shade number 9 | 0.8 | 0.3 | 0.1 | 210 | 120 | 60 |
| shade number 10 | 3.8 | 0.3 | 0.1 | 220 | 110 | 60 |
| shade number 11 | 1.0 | 0.3 | 0.1 | 220 | 110 | 60 |
| shade number 12 | 0.8 | 0.3 | 0.1 | 230 | 110 | 60 |
| shade number 13 | 0.8 | 0.3 | 0.1 | 230 | 110 | 60 |
| sample 14106-6 | | | | | | |
| shade number 9 | 0.7 | 0.2 | 0.2 | 250 | 130 | 60 |
| shade number 10 | 0.7 | 0.2 | 0.2 | 250 | 130 | 70 |
| shade number 11 | 0.7 | 0.2 | 0.2 | 250 | 130 | 70 |
| shade number 12 | 0.8 | 0.2 | 0.2 | 260 | 130 | 70 |
| shade number 13 | 0.8 | 0.2 | 0.2 | 270 | 130 | 70 |

Test mark: 11061-ECS-14

Type: LY600 / AWF variable shade

Angle dependence of luminous transmittance

| test ↓ | sample → | 14106 | | | | | |
|---|-----------------|-------|------|------|------|------|------|
| | | -1 | -2 | -3 | -4 | -5 | -6 |
| maximum transmittance ratio shade number clear | max. ratio | 1.00 | 1.00 | 1.01 | 1.01 | 1.00 | 1.01 |
| | max. reciprocal | 1.12 | 1.12 | 1.12 | 1.13 | 1.12 | 1.12 |
| maximal shade number _Δ at 30° | | 0.1 | 0.1 | 0.1 | 0.1 | 0.1 | 0.1 |
| class for the angle dependence of luminous transmittance | | 1 | 1 | 1 | 1 | 1 | 1 |
| minimal shade number at 15° to a clearer state AS/NZS requirement | | 4.1 | 4.1 | 4.1 | 4.1 | 4.2 | 4.2 |
| maximum transmittance ratio shade number 9 | max. ratio | 0.80 | 0.80 | 0.8 | 0.80 | 0.81 | 0.81 |
| | max. reciprocal | 2.08 | 2.10 | 2.09 | 2.01 | 2.04 | 2.19 |
| maximal shade number _Δ at 30° | | -0.8 | -0.8 | -0.8 | -0.8 | -0.8 | -0.8 |
| class for the angle dependence of luminous transmittance | | 1 | 1 | 1 | 1 | 1 | 1 |
| minimal shade number at 15° to a clearer state AS/NZS requirement | | 9.0 | 8.9 | 9.0 | 8.8 | 8.9 | 8.9 |
| maximum transmittance ratio shade number 10 | max. ratio | 0.76 | 0.75 | 0.77 | 0.76 | 0.77 | 0.78 |
| | max. reciprocal | 2.27 | 2.23 | 2.14 | 2.19 | 2.21 | 2.34 |
| maximal shade number _Δ at 30° | | -0.7 | -0.8 | -0.7 | -0.8 | -0.8 | -0.8 |
| class for the angle dependence of luminous transmittance | | 1 | 1 | 1 | 1 | 1 | 1 |
| minimal shade number at 15° to a clearer state AS/NZS requirement | | 9.9 | 9.9 | 10.0 | 9.8 | 9.8 | 9.5 |

Continued at the next page!

| | |
|------------|----------------------------|
| Test mark: | 11061-ECS-14 |
| Type: | LY600 / AWF variable shade |

Angle dependence of luminous transmittance (continued)

| test ↓ | sample → | 14106 | | | | | |
|---|-----------------|-------|------|------|------|------|------|
| | | -1 | -2 | -3 | -4 | -5 | -6 |
| maximum transmittance ratio shade number 11 | max. ratio | 0.76 | 0.73 | 0.76 | 0.73 | 0.74 | 0.74 |
| | max. reciprocal | 2.11 | 2.00 | 1.96 | 2.02 | 2.07 | 2.29 |
| maximal shade number _Δ at 30° | | 0.1 | 0 | 0 | -0.1 | -0.2 | -0.3 |
| class for the angle dependence of luminous transmittance | | 1 | 1 | 1 | 1 | 1 | 1 |
| minimal shade number at 15° to a clearer state AS/NZS requirement | | 11.1 | 11.0 | 10.9 | 10.9 | 10.8 | 10.8 |
| maximum transmittance ratio shade number 12 | max. ratio | 0.87 | 0.81 | 0.91 | 0.81 | 0.82 | 0.81 |
| | max. reciprocal | 1.68 | 1.54 | 1.45 | 1.52 | 1.51 | 1.76 |
| maximal shade number _Δ at 30° | | 0.7 | 0.7 | 0.8 | 0.7 | 0.6 | 0.5 |
| class for the angle dependence of luminous transmittance | | 1 | 1 | 1 | 1 | 1 | 1 |
| minimal shade number at 15° to a clearer state AS/NZS requirement | | 11.8 | 11.9 | 11.9 | 11.9 | 11.9 | 11.8 |
| maximum transmittance ratio shade number 13 | max. ratio | 1.20 | 1.11 | 1.17 | 1.11 | 1.11 | 1.18 |
| | max. reciprocal | 1.11 | 1.09 | 1.02 | 1.10 | 1.05 | 1.15 |
| maximal shade number _Δ at 30° | | 1.5 | 1.3 | 1.6 | 1.3 | 1.4 | 1.4 |
| class for the angle dependence of luminous transmittance | | 1 | 1 | 1 | 1 | 1 | 1 |
| minimal shade number at 15° to a clearer state AS/NZS requirement | | 12.7 | 12.7 | 12.7 | 12.7 | 12.7 | 12.7 |

Continued at the next page!

Test mark: 11061-ECS-14

Type: LY600 / AWF variable shade

Angle dependence of luminous transmittance (continued)

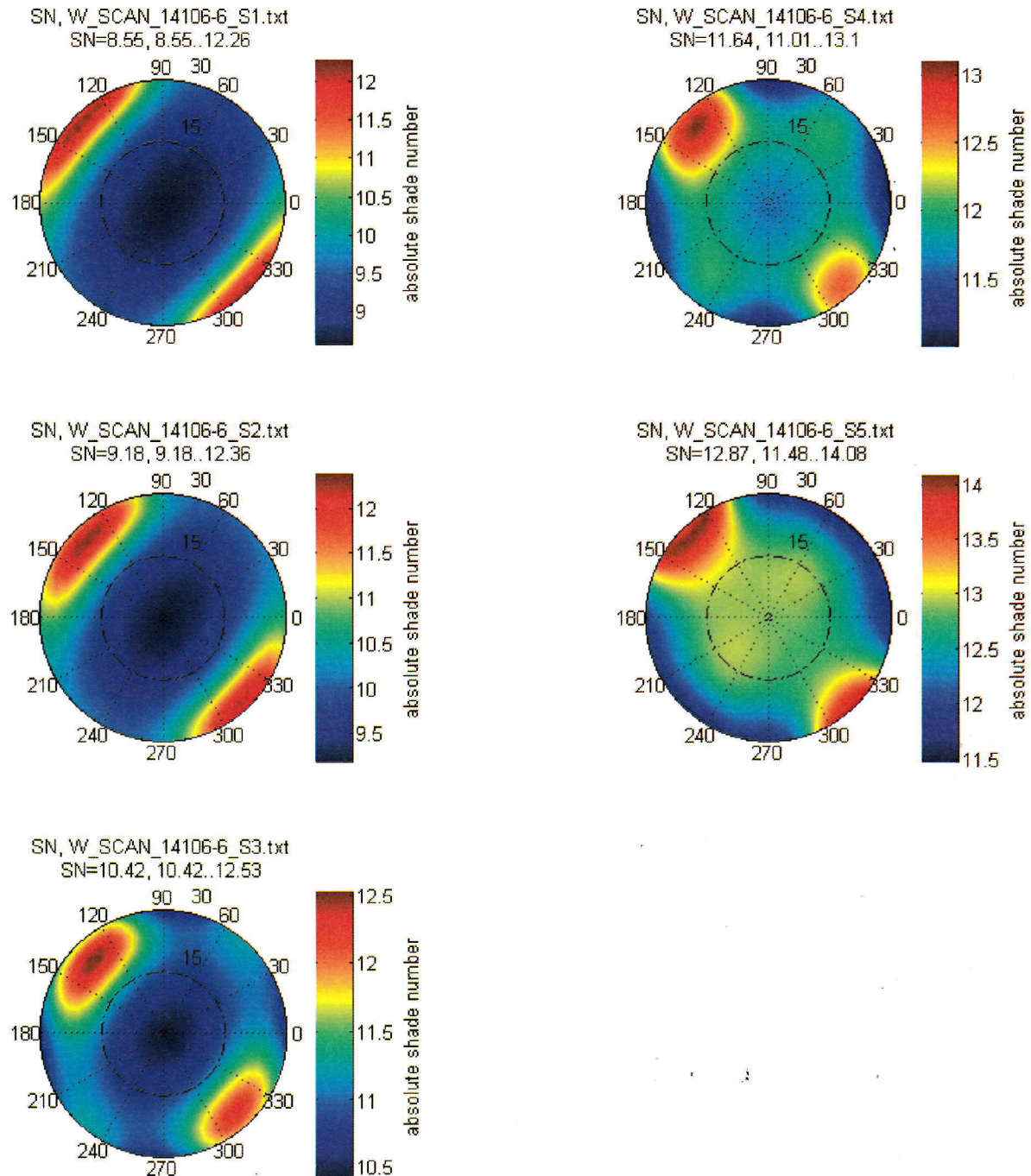

Figure 4: angle dependence measurement for sample 14106-6 for shade number 9 to 13 up to an angle of 30°. The dash-dotted line is showing the 15° limit.

Continued at the next page!

Test mark: 11061-ECS-14

Type: LY600 / AWF variable shade

Angle dependence of luminous transmittance (continued)

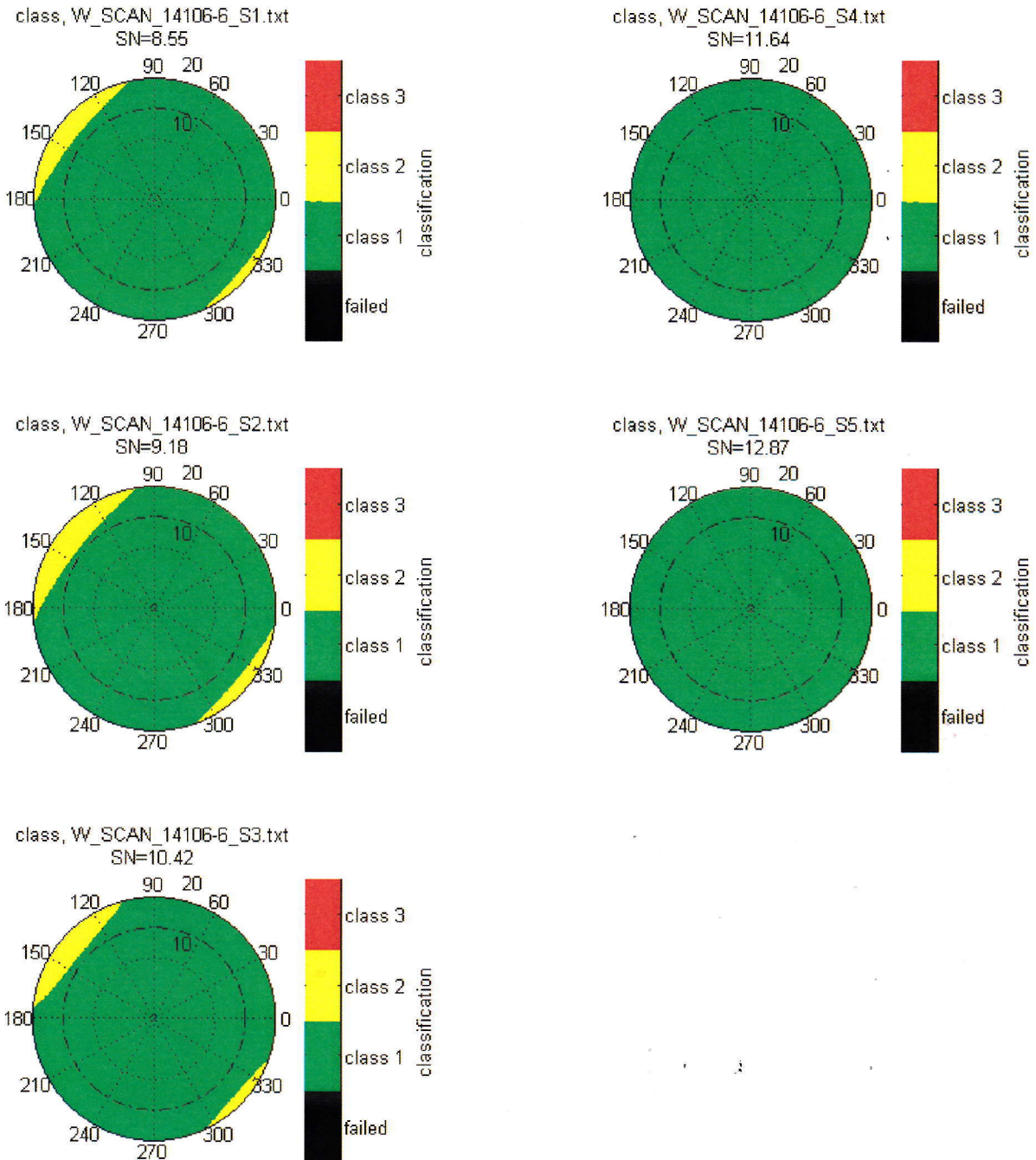

Figure 5: angle dependence EN classification for sample 14106-6 for shade number 9 to 13 up to an angle of 20°. The dash-dotted line is showing the 15° limit.

Continued at the next page!

Test mark: 11061-ECS-14

Type: LY600 / AWF variable shade

Angle dependence of luminous transmittance (continued)

The conversion between the *ratio*, *reciprocal* and *shade number*_Δ is

$$\text{shade number}_{\Delta} = +\frac{7}{3} \cdot \log(\text{ratio})$$

$$\text{shade number}_{\Delta} = -\frac{7}{3} \cdot \log(\text{reciprocal})$$

$$\text{shade number}_{\Delta} = \text{shade number}_{\text{normal}} - \text{shade number}_{\text{angle}}$$

A positive *shade number*_Δ means brighter and a negative value means darker

Coordinate system used for angle dependence measurements

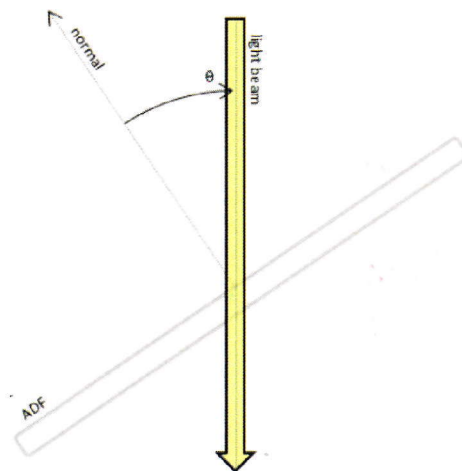
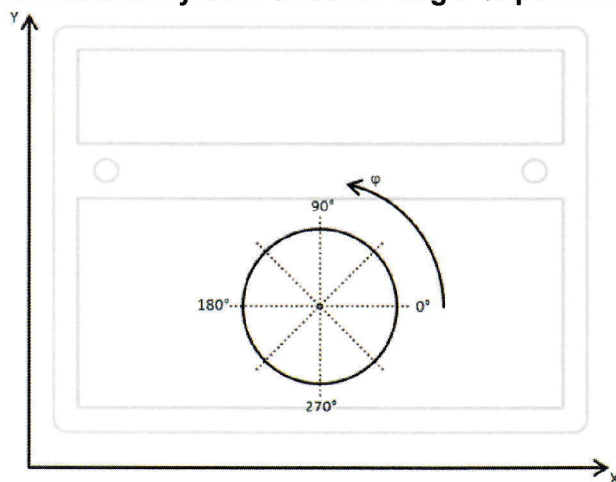

| | |
|------------|----------------------------|
| Test mark: | 11061-ECS-14 |
| Type: | LY600 / AWF variable shade |

Diffusion of light, transmittance, homogeneity, luminous transmittance with temperature, switching time after test to UV ageing

Diffusion of light / reduced luminance coefficient

| test ↓ sample → | | 14106 | | |
|--|-----------------------------------|-------|-----|-----|
| | | -1 | -2 | -3 |
| reduced luminance coefficient, diffusion of light, clear state | $\frac{\text{cd/m}^2}{\text{lx}}$ | 0.1 | 0.1 | 0.1 |
| diffusion of light class | | 1 | 1 | 1 |
| reduced luminance coefficient, diffusion of light, shade number 9 | $\frac{\text{cd/m}^2}{\text{lx}}$ | 0.1 | 0.1 | 0.1 |
| diffusion of light class | | 1 | 1 | 1 |
| reduced luminance coefficient, diffusion of light, shade number 11 | $\frac{\text{cd/m}^2}{\text{lx}}$ | 0.1 | 0.1 | 0.1 |
| diffusion of light class | | 1 | 1 | 1 |
| reduced luminance coefficient, diffusion of light, shade number 13 | $\frac{\text{cd/m}^2}{\text{lx}}$ | 0.2 | 0.2 | 0.1 |
| diffusion of light class | | 1 | 1 | 1 |

Continued at the next page!

| | |
|------------|----------------------------|
| Test mark: | 11061-ECS-14 |
| Type: | LY600 / AWF variable shade |

Filtering action

| test ↓ sample → | | 14106 | | |
|---|---|------------------------|------------------------|------------------------|
| | | -1 | -2 | -3 |
| luminous transmittance rel NA * horizontal orientation | % | 2.4 | 2.4 | 2.4 |
| calculated shade number | | 4.8 | 4.8 | 4.8 |
| nominal shade number | | 5 | 5 | 5 |
| spectral transmittance 210 nm ≤ λ ≤ 313 nm | % | ≤ 3*10 ⁻⁴ | ≤ 3*10 ⁻⁴ | ≤ 3*10 ⁻⁴ |
| spectral transmittance 313 nm < λ ≤ 365 nm | % | ≤ 4.4*10 ⁻⁴ | ≤ 4.4*10 ⁻⁴ | ≤ 4.4*10 ⁻⁴ |
| spectral transmittance 365 nm < λ ≤ 380 nm | % | ≤ τ | ≤ τ | ≤ τ |
| spectral transmittance 380 nm < λ ≤ 480 nm | % | ≤ τ _(480nm) | ≤ τ _(480nm) | ≤ τ _(480nm) |
| mean transmittance 780 nm ≤ λ ≤ 1400 nm | % | ≤ 0.014 | ≤ 0.014 | ≤ 0.014 |
| ISO/WD 16321 N141 | | | | |
| spectral transmittance 200 nm ≤ λ ≤ 313 nm | % | ≤ 3*10 ⁻⁴ | ≤ 3*10 ⁻⁴ | ≤ 3*10 ⁻⁴ |
| spectral transmittance 313 nm < λ ≤ 365 nm | % | ≤ 4.4*10 ⁻⁴ | ≤ 4.4*10 ⁻⁴ | ≤ 4.4*10 ⁻⁴ |
| blue-light transmittance | % | < 3.6 | < 3.6 | < 3.6 |
| spectral transmittance 365 nm < λ ≤ 380 nm | % | ≤ τ | ≤ τ | ≤ τ |
| mean transmittance 780 nm ≤ λ ≤ 1400 nm | % | ≤ 1 | ≤ 1 | ≤ 1 |
| mean transmittance 780 nm ≤ λ ≤ 3000 nm | % | ≤ 1 | ≤ 1 | ≤ 1 |

* measured in a spectrophotometer, whereat the light is partially polarized

Remark: the samples meet the requirements in the UV- and IR-range for the dark state already in the clear state.

Continued at the next page!

| | |
|------------|----------------------------|
| Test mark: | 11061-ECS-14 |
| Type: | LY600 / AWF variable shade |

Homogeneity, variations in luminous transmittance

| test ↓ | sample → | 14106 | | |
|--|----------|-----------|-----------|-----------|
| | | -1 | -2 | -3 |
| homogeneity, clear state, P1 | % | 8.3 | 7.1 | 5.0 |
| homogeneity, clear state, P2 | % | 8.4 | 7.3 | 5.5 |
| homogeneity, clear state, P3 | % | 0.5 | 0.1 | 0.6 |
| variations in luminous transmittance class | | 1 | 1 | 1 |
| measured shade numbers, limits | | 4.05-4.14 | 4.06-4.16 | 4.03-4.11 |
| homogeneity, shade number 9, P1 | % | 23.2 | 17.0 | 16.9 |
| homogeneity, shade number 9, P2 | % | 20.9 | 18.3 | 12.2 |
| homogeneity, shade number 9, P3 | % | 1.9 | 1.2 | 2.9 |
| variations in luminous transmittance class | | 3 | 2 | 2 |
| measured shade numbers, limits | | 8.67-8.90 | 8.57-8.82 | 8.69-8.88 |

Continued at the next page!

| | |
|------------|----------------------------|
| Test mark: | 11061-ECS-14 |
| Type: | LY600 / AWF variable shade |

Homogeneity, variations in luminous transmittance (continued)

| test ↓ | sample → | 14106 | | |
|--|----------|-------------|-------------|-------------|
| | | -1 | -2 | -3 |
| homogeneity, shade number 11, P1 | % | 22.7 | 16.4 | 20.1 |
| homogeneity, shade number 11, P2 | % | 23.0 | 14.4 | 14.9 |
| homogeneity, shade number 11, P3 | % | 1.6 | 1.1 | 1.9 |
| variations in luminous transmittance class | | 2 | 1 | 2 |
| measured shade numbers, limits | | 10.70-10.95 | 10.62-10.86 | 10.53-10.76 |
| homogeneity, shade number 13, P1 | % | 13.1 | 10.2 | 10.9 |
| homogeneity, shade number 13, P2 | % | 12.1 | 11.1 | 5.7 |
| homogeneity, shade number 13, P3 | % | 2.6 | 3.3 | 1.2 |
| variations in luminous transmittance class | | 1 | 1 | 1 |
| measured shade numbers, limits | | 12.89-13.06 | 12.80-12.98 | 12.87-13.02 |

Continued at the next page!

Test mark: 11061-ECS-14

Type: LY600 / AWF variable shade

Homogeneity, variations in luminous transmittance (continued)

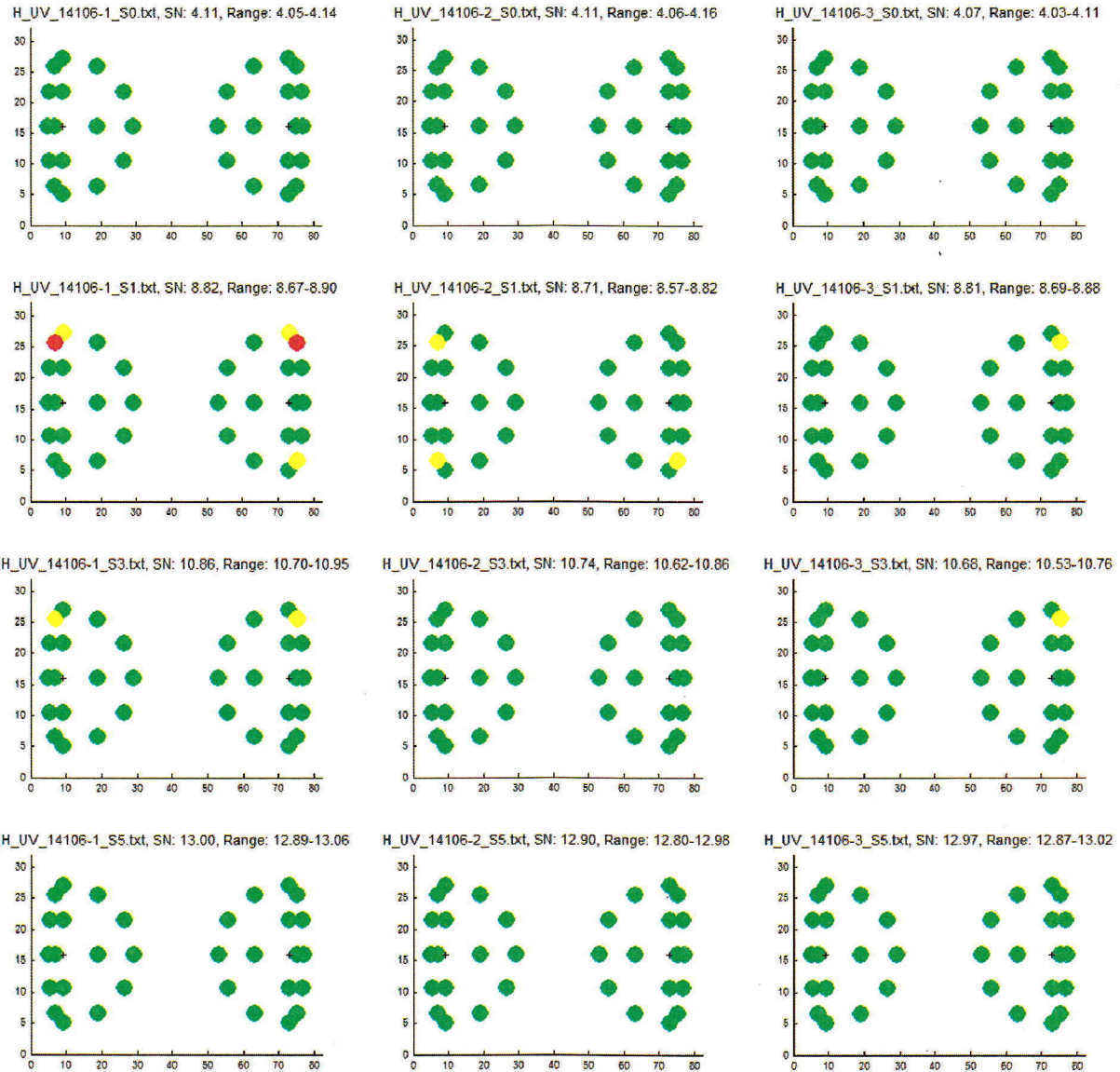

Figure 6: homogeneity classification for sample 14106-1, -2 and -3 for the shade numbers 4, 9, 11 and 13.

| | |
|------------|----------------------------|
| Test mark: | 11061-ECS-14 |
| Type: | LY600 / AWF variable shade |

Luminous transmittance / shade number at extremes of temperatures

| test ↓ sample → | 14106 | | |
|---|-------|------|------|
| | -1 | -2 | -3 |
| temperature: -5°C | | | |
| luminous transmittance / shade number clear | 4.1 | 4.1 | 4.1 |
| luminous transmittance / shade number 9 | 9.2 | 9.1 | 9.6 |
| luminous transmittance / shade number 11 | 11.1 | 11.0 | 11.1 |
| luminous transmittance / shade number 13 | 13.1 | 13.0 | 13.0 |
| temperature: +55°C | | | |
| luminous transmittance / shade number clear | 4.5 | 4.4 | 4.4 |
| luminous transmittance / shade number 9 | 8.8 | 8.4 | 8.7 |
| luminous transmittance / shade number 11 | 10.9 | 10.4 | 10.5 |
| luminous transmittance / shade number 13 | 12.1 | 12.4 | 12.8 |

Switching time

| Test ↓ sample → | | 14106 | | |
|---|----|-------|-----|-----|
| | | -1 | -2 | -3 |
| from shade 4 to 13 at temperature: -5 °C | ms | 0.7 | 0.8 | 0.8 |
| from shade 4 to 13 at temperature: +55 °C | ms | 0.1 | 0.1 | 0.1 |

Continued at the next page!

| | |
|------------|----------------------------|
| Test mark: | 11061-ECS-14 |
| Type: | LY600 / AWF variable shade |

Angle dependence of luminous transmittance

| test ↓ | sample → | 14106 | | |
|--|-----------------|-------|------|------|
| | | -1 | -2 | -3 |
| maximum transmittance ratio clear state | max. ratio | 1.01 | 0.99 | 1.01 |
| | max. reciprocal | 1.11 | 1.13 | 1.12 |
| maximal <i>shade number</i> _Δ at 30° | | 0.1 | 0.1 | 0.1 |
| class for the angle dependence of luminous transmittance | | 1 | 1 | 1 |
| maximum transmittance ratio shade number 9 | max. ratio | 0.79 | 0.79 | 0.80 |
| | max. reciprocal | 2.14 | 2.12 | 2.18 |
| maximal <i>shade number</i> _Δ at 30° | | -0.8 | -0.9 | -0.8 |
| class for the angle dependence of luminous transmittance | | 1 | 1 | 1 |
| maximum transmittance ratio shade number 11 | max. ratio | 0.77 | 0.73 | 0.75 |
| | max. reciprocal | 1.96 | 2.02 | 1.88 |
| maximal <i>shade number</i> _Δ at 30° | | 0.2 | 0 | 0.1 |
| class for the angle dependence of luminous transmittance | | 1 | 1 | 1 |
| maximum transmittance ratio shade number 13 | max. ratio | 1.25 | 1.13 | 1.20 |
| | max. reciprocal | 1.06 | 1.08 | 0.99 |
| maximal <i>shade number</i> _Δ at 30° | | 1.7 | 1.5 | 1.7 |
| class for the angle dependence of luminous transmittance | | 1 | 1 | 1 |

Test mark: 11061-ECS-14

Type: LY600 / AWF variable shade

Minimum robustness

| test ↓ | sample → | 14106 | | | | | | | |
|------------------|----------|-------|-----|-----|-----|-----|-----|-----|-----|
| | | -7 | -8 | -9 | -10 | -11 | -12 | -13 | -14 |
| thickness / mm | | 5.3 | 5.3 | 5.3 | 5.3 | 5.4 | 5.3 | 5.3 | 5.3 |
| test temperature | | RT | RT | RT | RT | RT | RT | RT | RT |
| results | | + | + | + | + | + | + | + | + |

Occlusion

| test ↓ | sample → | 14106 | | |
|--------|----------|-------|----|----|
| | | -1 | -2 | -3 |
| passed | | + | + | + |

Haze

Instead of haze, the EN-required diffusion of light / reduced luminance coefficient has been measured both in the clear and in the dark states.

Inflammability / resistance to ignition

| test ↓ | sample → | 14106 | | |
|--|----------|---|----|----|
| | | -7 | -8 | -9 |
| Inflammability, resistance to ignition | | temperature > 650 °C no ignition, no further glowing | | |

Aalen (Germany), 05 Sep. 14



 Dipl. Ing. (FH) Bastian Pedal
 ECS test engineer

Test Report

No. 1119-ECS-17

Contact person: Bastian Pedal
Phone: +49 (0)7361 9757399
Fax: +49 (0)7361 5562434
E-mail: bastian.pedal@ecs-eyesafe.de
Web: www.ecs-eyesafe.de

Test lab accredited by DAkkS D-PL-19590-02-00

Notified by the Central Authority of the Federal States for Safety Technologies (ZLS) ZLS-NB-0156

Customer

Jiangsu Meixin Optoelectronics
Technology Co. Ltd.
(Shanghai Lianya)
Hugang Industrial Zone
Xindian Town, Rudong
NANTONG CITY
JIANGSU PROVINCE
P.R.CHINA

Manufacturer

Test report contains

Main part and 1 measurement report

Number of pages in this test report

7

Product

Welding helmet, eye- and face protection
during welding and allied processes

Arrival of samples

Apr 19, 2017

Period of testing

May 04 – May 08, 2017

Test specifications (Standards)

DIN EN 175 : 1997

Remarks

Retests for recertification

The results described in this test report refer to the mentioned test samples, exclusively. A copy of the test report, complete or in extracts, is not allowed without any written permission of the ECS GmbH Aalen.

Aalen, 18 May 2017

Dipl. Ing. (FH) Bastian Pedal
ECS test engineer

Test objects, tests and results

Based on the tables as written in the standards DIN EN 175, the main part assigns the test samples to the named tests. The test results are documented according to the named standards.

Signs and symbols

The requirements are described in DIN EN 175

- + meet the requirements
- do not meet the requirements
- / not tested
- n.a. not applicable
- G borderline case
- Ab interruption of the testing sequence

Whenever the dioptric power of the surface is stated, this value was calculated using the formula $F=0,523/r$, where "r" is the radius of the curved surface.

The relative measurement uncertainties of the applied optical metrological instruments correspond to the required one in DIN EN 167.

Unless stated otherwise, the measurements were carried out in the main viewing point of the specimens and, in the case of lenses with corrective power, at the applicable reference point.

Test results

The annexes document the test results of each individual measurement. All results printed in bold and italic type document that the test sample did actually not meet the requirements which are demanded in the specified standards.

Samples and summary of the test results

| Type: | Welding helmet LYG-5 - face shield, eye and face protection during welding and allied processes | | | | | |
|--|---|---------------------------|------------|-----|--------|--------------------------|
| Test report: | 11191-ECS-17 | | | | | |
| Number of delivered samples: | 3 | 17119-3 will be archived. | | | | |
| Number of test samples: | 2 | | | | | |
| Test sequence | Requirement | Tests | | | | Samples 17119-1 to -2 |
| | | according to | | | | |
| | | EN | Clause | EN | Clause | |
| 1 | Marking | 175 | 9 | 175 | 9 | + |
| 2 | Information delivered by the manufacturer / applicant | 175 | 10 | 175 | 10 | + |
| 3 | Identity check | ./. | ./. | ./. | ./. | + |
| 4 | Design and assembly / material and manufacture | 175 | 4 | 175 | 4 | + |
| 5 | Area of coverage | 175 | 5.3 | 175 | 8.1 | + |
| 6 | Mass | 175 | 5.13 | 175 | 5.13 | + |
| 7 | Headband / fixture | 175 | 6 | 175 | 6 | + |
| 8 | Cleaning and disinfection | 175 | 5.12 | 175 | 5.12 | + |
| 9 | Light tightness / light reflectance | 175 | 5.6 / 5.7 | 175 | 8.4 | + |
| 10 | Resistance to ignition / resistance to hot penetration | 175 | 5.9 / 5.10 | 168 | 7 | + |
| 11 | Resistance to damage when dropped | 175 | 5.5 | 175 | 8.2 | + |
| 12 | Protection against high-speed particles, low energy impact (F) | 175 | 7.1 | 168 | 9 | + |
| See the measurement report 1 for the individual results of each test sample. | | | | | | |

| | |
|------------|--|
| Test mark: | 11191-ECS-17 |
| Type: | Welding helmet LYG-5, face shield, eye and face protection during welding and allied processes |

This measurement report extends 11741-ECS-12 for renewal of CE-certification.

Measurement report 1

Description of the type

Design:



Figure 1: Welding helmet LYG-5

Safety helmet, face shield for eye and face protection during welding and allied processes.

Welding helmet is equipped with a automatic darkening filter, a clear cover plate and a clear inside plate. Both plates are made of polycarbonate.

Welding filter, cover plate and inside plate are replaceable.

| | |
|------------|--|
| Test mark: | 11191-ECS-17 |
| Type: | Welding helmet LYG-5, face shield, eye and face protection during welding and allied processes |

| | | |
|---|-------------------------------------|--|
| Frame, helmet: | identification mark: | MEIXIN EN 175 F 510g CE |
| | material: | polypropionate |
| Filter / AWF: | | LY500A |
| | identification mark: | SHADE 4/9-13 CE EN379 ANSI Z87.1 |
| | shade: | 4/9-13 |
| | material: | Glass, laminated glass |
| | filter dimensions / mm ² | 93 x 43 |
| | filter thickness / mm: | 4.8 ± 0.1 |
| | | Filters provide an external shade control. |
| Cover plate: | identification mark: | Cover plate is not marked. |
| | material: | polycarbonate |
| | dimensions / mm | 110 * 90 |
| | thickness / mm: | 1.0 ± 0.05 |
| Back, inside plate: | identification mark: | Back plate is not marked. |
| | material: | polycarbonate |
| | dimensions / mm ² | 104 * 47 |
| | thickness / mm: | 1.0 ± 0.05 |
| Additional information delivered by the manufacturer: | bill of materials / user manual | |
| Identity to welding helmet measured in 11741-ECS-12 | + | |

| | |
|------------|--|
| Test mark: | 11191-ECS-17 |
| Type: | Welding helmet LYG-5, face shield, eye and face protection during welding and allied processes |

Design and assembly

| | |
|--|---|
| Design and assembly | meet the requirements for: common design, field of vision, area of coverage, material, finish and material quality |
| Dimensions | height / mm: 344 depth / mm: 184 width / mm: 212 meet the requirement, + |
| Area of coverage | meet the requirement, + |
| Protection against heat and electric shock | meet the requirement, + |
| Cleaning and disinfection | not specified, meet the requirement, + |
| Skin kindness | not specified, no observations |
| Headband | headband > 10 mm |
| Light tightness of housing | YES |
| Light reflectance | matt finished surface inside: meet the requirement, + |
| Mounting of filter and filter covers | meet the requirement, + |
| Metal components | no bare metal components + |
| Mass (excl filter) | 312 g, meet the requirement, + |

| | |
|------------|--|
| Test mark: | 11191-ECS-17 |
| Type: | Welding helmet LYG-5, face shield, eye and face protection during welding and allied processes |

Resistance of welder's shield to damage when dropped

| sample ↓ | test temperature / °C | test series | light compact | remarks |
|----------|-----------------------|-------------|---------------|---------|
| 17119-1 | -5°C | 1. fall | YES | none |
| | -5°C | 2. fall | YES | |
| | -5°C | 3. fall | YES | |

Inflammability / Resistance to ignition / Resistance to penetration of a hot rod

| test ↓ | sample → | 17119 | |
|--|----------|--|----|
| | | -1 | -2 |
| Inflammability, resistance to penetration of a hot rod | | temperature > 650 °C no ignition, no further glowing, no penetration of the hot rod within measurement time of 5 sec. | |

Protection against high-speed particles / resistance to energy impact

| sample ↓ | test → | test temperature / °C | test point | speed / m/s | results |
|----------|--------|-----------------------|---|-------------|---------|
| 17119-2 | | RT | left & right frontal, left and right side | ≥ 45 | + + + + |

- End of measurement report 1 -

EC-type examination certificate

C1493.3MEIXIN

| | |
|------------------------------------|---|
| Applicant / manufacturer | Jiangsu Meixin Optoelectronics Technology Co. Ltd. (Shanghai Lianya) Hugang Industrial Zone Xindian Town, Rudong NANTONG CITY JIANGSU PROVINCE P.R.CHINA |
| Identification of the manufacturer | MEIXIN |
| Product type | Face shield – Welding helmet |
| Model name | LYG-5 |
| Standard(s) / technical rules | DIN EN 175 : 1997 Annex II of the PPE-Directive 89/686/EEC |
| Test report | 11741-ECS-12, 1119-ECS-17 / MR 11191-ECS-17 |
| Material & specifications | polypropionate, safety plates, automatic welding filter, protection against high-speed particles, low energy impact (F) |
| Marking | MEIXIN EN175 F 510g CE |

Herewith, ECS certifies that the named model complies with the basic requirements for health and safety as they are provided by the European Directive for Personal Protective Equipment 89/686/EEC. This certificate is based both / either on the test results as they are summarized in the named test reports, and/or on the technical documentation as it is delivered by the manufacturer. The applicant / manufacturer agree to the General Business Rules of the ECS GmbH and to additional agreements as they are named in the application for conformity assessment.

The eye-protection device is to be marked as assigned. Either / both the frame and / or the ocular, spectacle, goggle or shield must be signed, as appropriate. If different marking has been assessed, the lowest marking must be applied, respectively. The validity of this EC-type examination will expire on the date as mentioned below, and if the manufacturer modifies the safety-relevant properties of this product with comparison to the tested one or if the requirements in the standards or technical rules will be revised and/or tightened.

Name, address and identification number 1883 of the notified body ECS are to be indicated in the information brochure of this product.

This EC-type examination certificate is valid until 2022-03.

ECS GmbH
Notified Body 1883
18/05/17

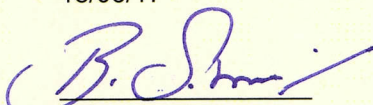
Dr. Bernhard Schmitz
ECS-Certification



ECS GmbH – European Certification Service
Augenschutz und Persönliche Schutzausrüstung
Laserschutz und Optische Messtechnik
Hüttfeldstraße 50
73430 Aalen, Germany